



Heading Control System

PilotStar D





Heading Control System

PilotStar D

PilotStar D is the professional autopilot recommended for all classes of ships up to a length of 120 m. Due to most advanced steering algorithms PilotStar D is well known in the market for its excellent steering performance, accuracy and reliability.

PilotStar D is used in heading or track control in combination with an external navigation receiver. It can easily be adapted manually or by predefined parameter sets to the current environmental or ship condition and adapts automatically to ships speed. A constant rudder trim can be defined to compensate for drift. FIX TURN allows to perform a definable heading change to port or starboard by simply clicking a button – an important feature for workboats.

PilotStar D offers various interfaces that make an installation on newbuildings and retrofit applications quick and simple. Heading is input from magnetic compass (as NMEA telegram or via magnetic compass sonde) and gyro compass. Speed information is input as pulse or serial telegram. In addition the autopilot provides an interface for a central alarm system. An alarm is transferred to the central alarm panel and can be muted remotely. A steering repeater can be connected directly to PilotStar D to display both, the heading of magnetic or gyro compass.



FU tiller



NFU tiller

The operator unit provides clear indication of all necessary data and ease of use



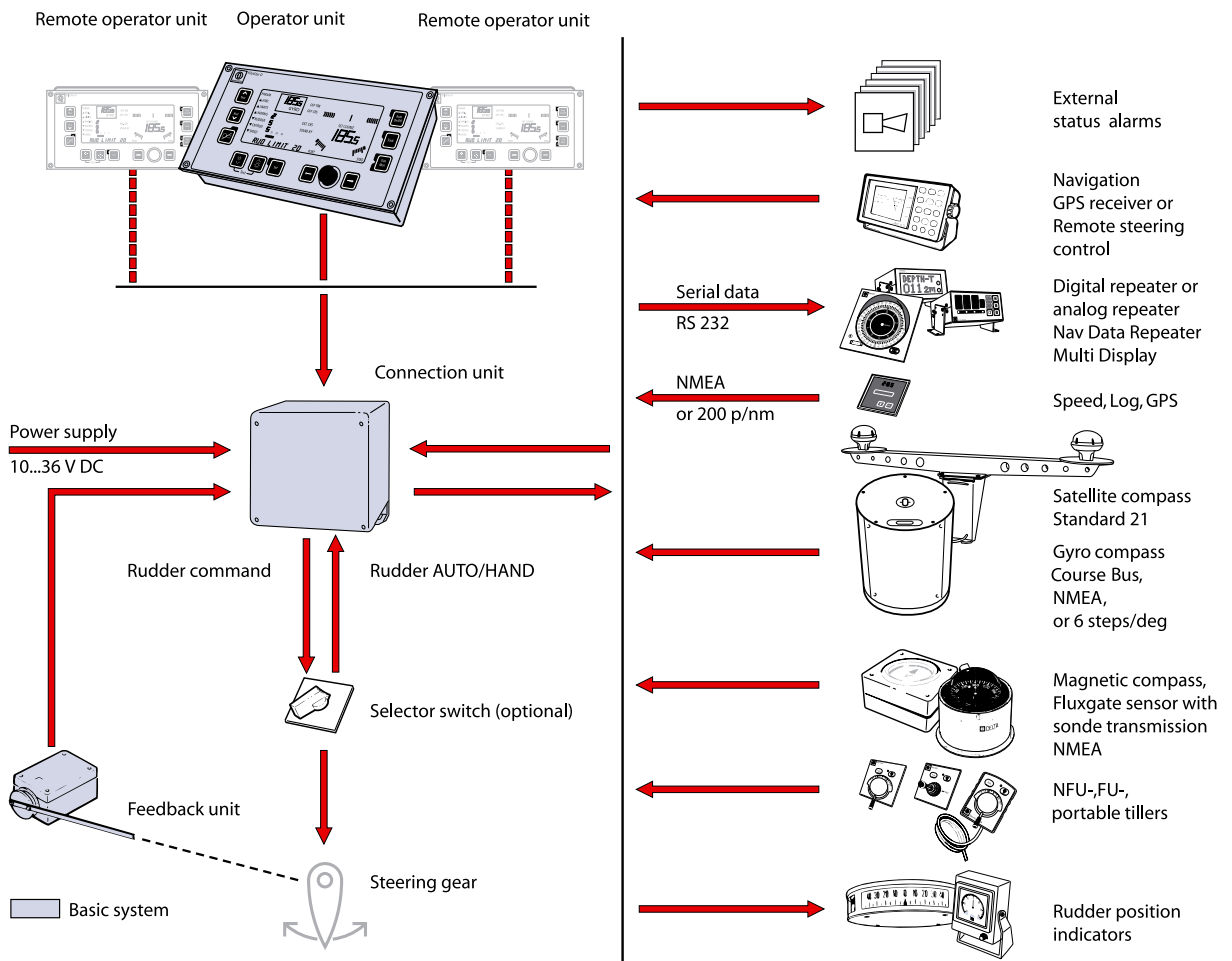

Feedback unit for professional vessels

Integration into a steering control system

PilotStar D is a versatile autopilot used in various system environments such as steering gears with switching and proportional solenoids, twin-rudders, rudder propellers and water jet drives. The PilotStar D can be extended by remote operator units, follow-up and non-follow-up tillers. These tillers are equipped with a take-over function to take over the control from the autopilot. Thus a remote steering control system is easily set up.



Feedback unit for yachts and workboats

Benefits

- Accurate steering
- Reliable technology installed on thousands of ships
- Ease of use and clear data display
- Remote operator units
- Suitable for all kind of ships even for High Speed Crafts
- Type approved as heading control system



Connection unit

Technical Data

Supply voltage

24 V DC (10-36 V DC)

Power consumption

Approx. 15 W

Signal inputs

Gyro compass / satellite compass

- Course Bus
- NMEA telegrams HEHDT, GPHDT (9600 Bd)
- 6 steps per degree

Magnetic compass

- NMEA telegram IHDMD
- With magnetic compass sonde 108-010
- Fluxgate sonde sine/cosine

Speed log

- NMEA telegrams VTG, VHW
- 200 pulses/nm

Navigation receiver

- NMEA telegrams APA, APB, XTE
- Remote control with NMEA telegram HSC

Signal outputs

Outputs to steering gear

- 2 switching outputs (110 V DC – 0.5 A; 24 V DC – 2.0 A)
- 2 analog outputs (+/- 10 V DC – max. 5 mA)

Status/alarm outputs

- Off-heading
- Course monitor
- System failure
- Power failure
- Steering failure monitoring
- Bi-directional central alarm reset (optional)
- Tiller ON

In accordance with

- ISO 11674
 - NMEA according to EN/IEC 61162
 - EN/IEC 60945
 - A.342(IX), A.694(17), MSC.64(67) Annex 3, A.822(19)
- For details refer to EC-type examination certificate.

Type of enclosure acc. to IEC/EN 60529

- Operator unit: IP 56 (mounted)
- Connection unit: IP 22

Permissible ambient temperature

- Operation: -10°C to + 70°C (operator unit)
-10°C to + 55°C (connection unit)
- Storage: -20°C to + 70°C (operator unit)
-20°C to + 70°C (connection unit)

Operator unit 2.0 kg

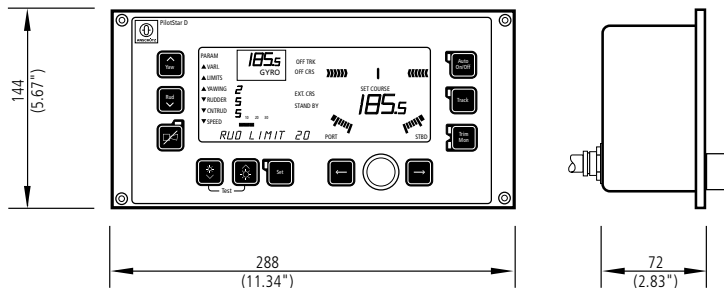

Connection unit 5.5 kg

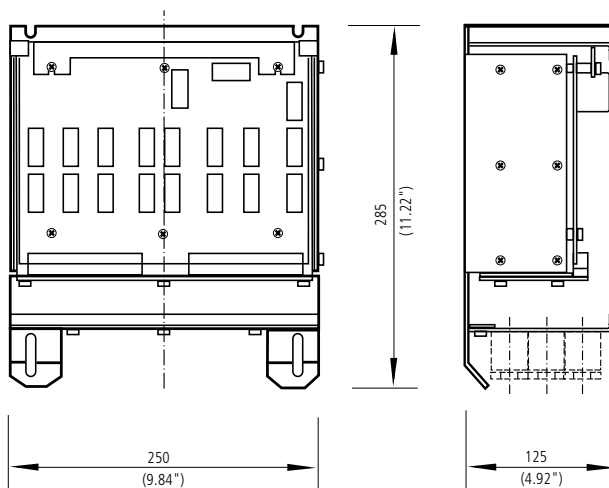

Feedback unit 0.9 kg

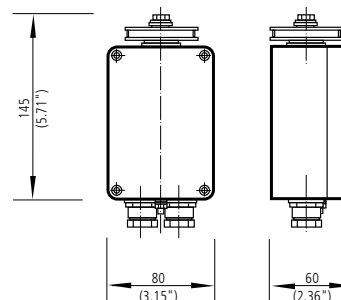

Feedback unit 5.0 kg

